

# MIDDLETOWN DESIGN

## *A Framework for Development*

Design Guidelines *for*  
The Middletown Design Review *and* Preservation Board

JULY, 2002 EDITION



THE MIDDLETOWN DESIGN REVIEW AND PRESERVATION BOARD  
*The Department of Planning, Conservation, and Development*  
City of Middletown Connecticut  
245 deKoven Drive  
Middletown, CT 06457

July, 2002



*The photos and illustrations in this guide are intended solely to identify design attributes and are in no way statements for or against individual properties, businesses, their owners, or tenants.*

design review & preservation board  
*Design Guidelines*

MIDDLETOWN DESIGN  
*A Framework for Development*

**Domenique S. Thornton, Mayor**

DESIGN REVIEW AND PRESERVATION BOARD

Jeff Bianco, Chairman  
 Mark Brady  
 David Brown  
 Patricia Evans  
 Jim Fortuna  
 Nancy Goff  
 Brian Kronenberger  
 Bruce Plumley  
 Nancy Stamler

William Warner, Director  
 Department of Planning, Conservation, and Development

Munro W. Johnson, Community Development Specialist; Author

ACKNOWLEDGEMENTS

These Design Guidelines were put together in partnership and consultation with numerous public officials, fellow members of the department, private citizens, and civic groups. Their honest opinions, sincere advice, and generous donations of time and resources are most appreciated. Additionally, many of the ideas, images, and portions of the text have been borrowed. For this, gratitude is extended to the Cities of Pittsburgh, PA, Northampton, MA, Manchester, CT, and Fort Collins, CO, and to Elizabeth Warner and the Greater Middletown Preservation Trust for images from *A Pictorial History of Middletown*, and to Allan Jacobs for drawings from his book *Great Streets*.



CITY OF MIDDLETOWN, CONNECTICUT 2002



Middletown, CT / MWJ

**G U I D E L I N E S :**  
 The following guidelines are the product of a collaborative effort between Middletown businesses, local government, and its citizens. The guidelines shall not have the force of law but rather function as a reference tool for members of the Design Review and Preservation Board, articulating a coherent and commonly-held design vision for the City of Middletown. Guidelines stated in this document shall be used to benefit the public interest in attaining and preserving a healthy, vibrant, and appealing community and business environment.

design review & preservation board  
*Design Guidelines*

Middletown, CT / MWJ



4

**G U I D E L I N E S :**

Guiding criteria for review by the Board, referred to throughout the following pages, are: scale (is the project's scale appropriate to Middletown and the project's neighbors), context (does the design for the project fit in well with its surroundings), coherence (does the project, when taken with the goals stated in these Guidelines, the Plan of Development, and other key public documents, contribute to a coherent vision for the development of the city), and character (does the project's design either maintain or improve the character of its neighborhood).

## INTRODUCTION

Middletown is greater than the sum of its parts. It is a 350-year old, traditional New England, Connecticut River Valley community, with a rich history and proud heritage. It possesses a unique downtown, a vital business community, and a rich stock of natural resources and preserves.

These qualities are shared qualities, and their perpetuation requires a shared effort. To preserve and protect the history, heritage, and aesthetic resources that together form much of the quality of life in our city, the citizens of Middletown, both directly and through their duly appointed representatives and officials, have produced this document as a framework and reference point for reviewing projects proposed in commercial and downtown areas of the city.

With this document, peoples' projects which entail physical improvements, new construction, or demolition in Middletown's most visible areas will be reviewed by a set of design principles and guidelines that have been established and articulated by their fellow residents and printed in the following pages. With these principles and guidelines in hand, the Design Review and Preservation Board can review projects with fairness and consistency.

Conversely, residents and developers whose projects are subject for review, are now afforded a measure of predictability in the knowledge that the judgment of the Board will be based on their project's conformance with the letter and spirit of the principles and guidelines contained in this document.

## CONTENTS

INTRODUCTION	4
AREAS SUBJECT TO REVIEW	5
HISTORIC PRESERVATION	12
MIX OF USES	13
THE STREET	14
CONTEXTUAL DEVELOPMENT	19
URBAN GREENERY	20
UPSTAIRS / DOWNTOWN	21
SIGNAGE	22
APPENDICES	31
A. DRPB ESTABLISHMENT	31
B. HISTORIC SITE ZONING	32
C. VILLAGE DIST. ACT	33
D. VILLAGE DIST. ZONING	35
E. SUMMARY OF DOI GUIDE	38
F. LARGE RETAIL	40
G. PERMIT PROCEDURE	56



# Design Guidelines

## AREAS SUBJECT TO REVIEW

The Board reviews all signage projects, as well as historic properties. Projects in the following areas are also subject to review by the Board:

1. Downtown Middletown  
*DeKoven Dr., to Broad St.; Hartford Ave. / Spring St., to Union St.*
2. Downtown Village District  
*Broad St., to High St.; Washington St., to Loveland St.*
3. Washington St. / Rt. 66 Corridor  
*All properties fronting on Washington St. / Route 66*
4. Newfield St. / Rt. 3 Corridor  
*All properties fronting on Newfield St. / Route 3*
5. South Main St. / Rt. 17 Corridor  
*All properties fronting on South Main St. / Route 17*
6. Saybrook Rd. / Rt. 154 Corridor  
*All properties fronting on Main St. Extension, East Main Street, or Saybrook Rd. / Route 154*
7. Waterfront Development Area  
*Union St. to Eastern Dr., Silver St. to River Road*



CITY OF MIDDLETOWN, CONNECTICUT 2002

## GUIDELINES :

Per section 26-10 of the Middletown Code of Ordinances, the Design Review and Preservation Board shall "...review designs... in business zones..." Areas subject to review will therefore include Middletown's downtown, its Village District, and the Route 3, Route 17, Route 154, and Route 66 corridors.

Per Sections 39D and 44 of the Middletown Zoning Code, the Board shall also review all projects affecting historically significant property.

design review & preservation board  
*Design Guidelines*

Middletown, CT / MWJ



Amsterdam / Unknown



Middletown, CT / MWJ



Middletown, CT / MWJ

6

G U I D E L I N E S :

Development in the DMT, DVD, & WFD areas should primarily appeal as pedestrian environments.

AREA CHARACTERISTICS AND GOALS

The Design Areas discussed in the Guidelines can be broadly defined in two categories: those that are and/or should be essentially pedestrian-friendly environments (i.e., Downtown Middletown, the Downtown Village District, and the Waterfront District), and those that are given more to automobile-oriented development (i.e., Rt.s 66, 3, 17, and 154).

*Downtown Middletown*



As Middletown's historic center, the Downtown Middletown area is the most aesthetically sensitive of all the design review areas. Buildings of special historical value are concentrated here, the city's retail, financial, and government centers are located here, and for outside visitors who visit "Middletown," it is this area in particular that they most frequently come to and take away impressions of when they leave.

Everything said in the following pages regarding historic preservation, mixed use development, streets, contextual development, urban greenery, upstairs downtown, and signage, is said with this area foremost in mind.

*Downtown Village District*



Located between the downtown and Wesleyan University, the Village District is primarily residential with a growing number of home offices or converted office uses and a handful of retail establishments. The building stock is overwhelmingly historic residential and the district's

C O N T E N T S

INTRODUCTION	4
AREAS SUBJECT TO REVIEW	5
HISTORIC PRESERVATION	12
MIX OF USES	13
THE STREET	14
CONTEXTUAL DEVELOPMENT	19
URBAN GREENERY	20
UPSTAIRS / DOWNTOWN	21
SIGNAGE	22
APPENDICES	31
A. DRPB ESTABLISHMENT	31
B. HISTORIC SITE ZONING	32
C. VILLAGE DIST. ACT	33
D. VILLAGE DIST. ZONING	35
E. SUMMARY OF DOI GUIDE	38
F. LARGE RETAIL	40
G. PERMIT PROCEDURE	56



design review & preservation board  
*Design Guidelines*

unique zoning designation (see Appendix D) gives the Board special powers of historic preservation with respect to properties in this area.

The primary goal with respect to the Village District is the preservation of the district’s historic character and balanced mix of residential and other uses. As one of the few remaining downtown residential areas, design and development in the area should be encouraged in a manner supportive of its continuance as a residential neighborhood.



*Waterfront District*

The Waterfront District area is that area designated for the Waterfront Development Initiative. Plans to rezone the area, develop a detailed land use plan, and conceptual architectural renderings are currently underway, and when completed, will more specifically articulate the design standards for this area.

Thus far, a public participation and charrette process for the waterfront’s development has identified some criteria for the project which should act as a conceptual framework for design in this area:

- An active and comfortable pedestrian environment
- A primary emphasis on proximity and views to river
- Scale all development to match context and reflect current character of downtown
- Streetscape elements including lighting, landscaping, and pavement textures
- Integrate natural areas such as brooks and wetlands into a greenbelt park system

A brochure entitled “Riverfront Renaissance” summarizes many of the goals and objectives identified and agreed to in the community charrettes held to date, and includes a conceptual plan for the 85 waterfront acres.



Middletown, CT / Virginia Welch



Middletown, CT / Planimetrics



Middletown, CT / Arthur Cotton Moore / Associates



G U I D E L I N E S :

In the Waterfront District, scale, streetscape elements, and waterfront access should be oriented to the pedestrian. Proximity of parking facilities is of secondary importance to creating an overall pedestrian environment for the area.

Middletown, CT / MWJ



8

## G U I D E L I N E S :

The commercial corridors -- Routes 66, 17, 3, and 154 -- are essentially auto-designated spaces and should be reviewed with the motorist foremost in mind.

### Route 66 Corridor



The Washington Street / Route 66 Corridor is a major arterial, Middletown's primary commercial strip corridor, and like Rts. 3, 17, and 154, functions as the context for a very different style -- and scale -- of development from that in the design areas discussed above. Appendix F: Architectural Guidelines for Large Retail Establishments addresses in detail architectural and parking strategies for enhancing the visual quality of big box development along these corridors.

From the point of Wesleyan's frontage on Washington Street, downhill to the east and the intersection with Main Street, a handful of residential structures, along with some other atypical uses such as the Kidcity Children's Museum and residential-professional office conversions remain. This softer end of Washington Street, however, is delicately poised alongside the convergence of heavy traffic volume at the intersection with Main Street. Downhill to the west, on the north side of the street, exists a row of residential buildings in varying degrees of upkeep. The road then passes under a railroad overpass, at which point visual chaos and clutter ensues. The rest of the Washington Street/Route 66 Corridor is characterized by predominantly automobile-oriented, strip development such as gas stations, fast-food restaurants, and shopping plazas offering abundant on-site, surface parking, almost none of which has contributed to an aesthetically pleasing business environment. Sidewalks are narrow, intermittent, and often crumbling and overgrown with weeds. Parking lots, too, are often pocked with holes in unmaintained asphalt, weeds, and disorderly circulation, endangering both cars and pedestrians arriving and leaving.

## CONTENTS

INTRODUCTION	4
AREAS SUBJECT TO REVIEW	5
HISTORIC PRESERVATION	12
MIX OF USES	13
THE STREET	14
CONTEXTUAL DEVELOPMENT	19
URBAN GREENERY	20
UPSTAIRS / DOWNTOWN	21
SIGNAGE	22
APPENDICES	31
A. DRPB ESTABLISHMENT	31
B. HISTORIC SITE ZONING	32
C. VILLAGE DIST. ACT	33
D. VILLAGE DIST. ZONING	35
E. SUMMARY OF DOI GUIDE	38
F. LARGE RETAIL	40
G. PERMIT PROCEDURE	56





*Design Guidelines*

While design for the downtown, the waterfront, and the village district should emphasize and primarily appeal to the pedestrian, Route 66 has a separate role in the city and design for it should emphasize and primarily function for vehicular traffic. Significant sections of Route 17, 3, and 154 are similar in this regard and what follows below shall apply to them also.

But, while recognizing the fundamental difference in role, function, and style of commercial corridor development from that of the other design areas discussed above, one must also recognize the extent to which attention to design along the corridor has been lacking over the years, and the consequent aesthetic damage on these important economic gateways into Middletown. Lax standards for design may seem “business-friendly” at the time of a developer’s application, but in the long term, it contributes to a shoddy overall business environment which weighs down the economic potential of the area, and of the city as a whole.

Acknowledging that people passing through a visual environment from inside an automobile hold the landscape to less exacting aesthetic standards than do people on foot, design review for this corridor should be alternatively strict and permissive, depending on the opportunity for improvement inherent in a project’s scope. Simple replacement or refacing of sign “slots” or panels within existing plazas and/or their composite free-standing signs, shall not require review by the Board. A change of the composite free-standing sign itself, a significant change of a building’s use, renovation, and/or new construction projects however, shall all occasion a review by the Board with an eye toward improving the aesthetics of the corridor per the Standard’s & Guidelines provided in Appendix F.



## G U I D E L I N E S :

Review of projects in the commercial corridors should be alternatively strict and permissive, depending upon the opportunity for improvement inherent in a project’s scope. Simple refacings or slot replacements of composite signs shall receive routine staff-level approvals. Change of the sign itself or change of building use or new construction shall occasion a review by the Board with an eye toward improving the corridor’s aesthetics per the standards in Appendix F.

## CONTENTS

INTRODUCTION	4
AREAS SUBJECT TO REVIEW	5
HISTORIC PRESERVATION	12
MIX OF USES	13
THE STREET	14
CONTEXTUAL DEVELOPMENT	19
URBAN GREENERY	20
UPSTAIRS / DOWNTOWN	21
SIGNAGE	22
APPENDICES	31
A. DRPB ESTABLISHMENT	31
B. HISTORIC SITE ZONING	32
C. VILLAGE DIST. ACT	33
D. VILLAGE DIST. ZONING	35
E. SUMMARY OF DOI GUIDE	38
F. LARGE RETAIL	40
G. PERMIT PROCEDURE	56

Middletown, CT / MWJ



Middletown, CT / MWJ



10

### GUIDELINES:

Route 3 Goal: Gradual and orderly transition from a primarily residential street to a commercial corridor.

Route 17 Goal: Guide development in ways that preserve the character of each of three sections, i.e., South Green to Sumner Brook, Sumner Brook to Randolph Road, and Randolph Road to the Durham and Middlefield boundaries.



### Route 3 Corridor

The Route 3 / Newfield Street Corridor is the northeast gateway into Middletown and, like Routes 66, 17, and 154, hosts a wide array of land uses, from single family residential, to car dealerships.

The Route 3 / Newfield Street Corridor, like sections of Routes 17 and 154, bears the scars of a roadway that, due to shifting traffic patterns, has undergone a rapid transition in function, from being a primarily residential street, to a commercial corridor, prior to controls being put in place to guide its development. The resulting chaotic visual appearance is due to abrupt changes in land use, inconsistent sidewalks, and traffic speeds and volumes that exceed what is comfortable for a once-residential area. The primary goal for this corridor is a more gradual and orderly transition than what is currently underway.



### The Route 17 / South Main Street Corridor

Proceeding from the edge of South Green past Middlesex Hospital, to Sumner Brook, then on to Randolph Road and beyond, this corridor transitions from residential and office uses, to intense commercial development, and ultimately, to rural landscapes. The primary goal for this corridor is to guide development in ways that are sensitive to the character of each of these three sections. Retail development in the middle section -- from Sumner Brook to Randolph Road -- should comply with the Standards & Guidelines described in *Appendix F*.



*Design Guidelines**Saybrook Road / Rt. 154 Corridor*

East Main Street, Main Street Extension, the intersection where they converge, and the Route 154 Corridor that follows, form the last design review area.

Architectural evidence of a time when Main Street and the downtown core were still expanding, the development along East Main Street and Main Street Extension is a cross between downtown overflow and that of a historical mixed use neighborhood. Further south, Route 154 development consists of predominantly professional offices, with periodic interruptions of retail or residential uses. City plans call for further such development in this corridor, especially of medical offices, to tie in with medical facilities currently located there. Design goals include a cleaner, more uniform look for the corridor, with improved streets and more consistent lot orientation.

*Financing and Implementation*

Where concerns over cost arise in the implementation of these goals, Board members should be proactive and encourage applicants for new construction or significant renovation of commercial corridor properties to set aside a designated maintenance/upkeep fund. Where a subject improvement in question actually sits on city property (e.g., sidewalks), the Board should advocate for policies whereby a portion of developer fees is set aside and dedicated to the upkeep and maintenance of those areas of the property which, although geographically associated with a private parcel, are in fact public in ownership and in their visual affect on the entire corridor.



Middletown, CT / MWJ



Middletown, CT / MWJ



## G U I D E L I N E S :

Route 154 Goal: Cultivate a cleaner, more uniform look for the corridor, with improved streets and more consistent lot orientation.

Middletown, CT / MWJ



12

## GUIDELINES :

When construction, rehabilitation or physical development projects occur in Middletown's business zones and is pertinent to issues of Historic Preservation, the Board will refer to *The Secretary of the Interior's Standards for the Treatment of Historic Properties, with Guidelines for Preserving, Rehabilitating, Restoring, & Reconstructing Historic Buildings*, available online, at the library, or in the Department of Planning, Conservation, & Development.

## HISTORIC PRESERVATION

Middletown's 350 years, scores of nationally registered and eligible historic properties, and seven historic districts all comprise a compelling argument for residents to take extra care to protect their ultimate shared community resource: history.

In the interests of protecting and promoting to the utmost Middletown's historic resources, projects dealing with historic properties will be held to national standards. The National Department of the Interior has published a document, to which the Design Review and Preservation Board will refer when reviewing projects proposed for Middletown historic properties:

*The Secretary of the Interior's Standards for the Treatment of Historic Properties, with Guidelines for Preserving, Rehabilitating, Restoring, & Reconstructing Historic Buildings*

This document is available locally at the reference desk of the Russell Library, Middletown's Department of Planning, Conservation, & Development, or online at the Department of the Interior's website: <http://www2.cr.nps.gov/tps/standards/index.htm>. A summary of the same is provided in Appendix E.

## CONTENTS

INTRODUCTION	4
AREAS SUBJECT TO REVIEW	5
HISTORIC PRESERVATION	12
MIX OF USES	13
THE STREET	14
CONTEXTUAL DEVELOPMENT	19
URBAN GREENERY	20
UPSTAIRS / DOWNTOWN	21
SIGNAGE	22
APPENDICES	31
A. DRPB ESTABLISHMENT	31
B. HISTORIC SITE ZONING	32
C. VILLAGE DIST. ACT	33
D. VILLAGE DIST. ZONING	35
E. SUMMARY OF DOI GUIDE	38
F. LARGE RETAIL	40
G. PERMIT PROCEDURE	56



*Design Guidelines*

## MIX OF USES

While acknowledging that some land uses are clearly incompatible, current planning practice also recognizes that mixed use development -- especially in downtowns -- best supports the functions of daily life: employment, recreation, retail, and civic and educational institutions. Such mixes foster vibrant, interesting communities.

Areas which include office, retail, and housing uses within the same neighborhood -- or even within the same building -- are no longer regarded as potential risks for nuisance, but as opportunities for synergy.

Indeed, ever larger segments of the housing consumer market actively seek out those locations where they can walk to work, to the store, and at the same time avail themselves of neighborhood parks and entertainment. Residential uses tend to soften the edges of a strictly retail district while retail can benefit from a local customer base of nearby residents or office workers.



## G U I D E L I N E S :

The Board shall, in keeping with stated design criteria, encourage wherever possible the preservation, promotion, and increase of mixed use buildings and districts in business zones.



design review & preservation board  
*Design Guidelines*

THE STREET

Much of Middletown's public space in the downtown is, in fact, its streets. Parking places, sidewalks, and intersections are all places where people utilizing different modes of transportation converge. Pedestrians, busses, cars, wheelchairs, bicycles, strollers, motorcycles, rollerskates, skateboards -- and the people on or in them -- all must find ways to accommodate one another in the city's streets.

One strategy for addressing this challenge is to simply do nothing and allow people to dodge, bob, and weave to the best of their ability, hopefully becoming neither the cause nor the victim of an accident.

An opposite strategy is to divide clearly -- and fairly -- street space for the chief modal categories of cars, bicycles, and pedestrians (see photo top left). As Middletown grows and plans for its streets, citizens should keep in mind that larger cities have found ways of further dividing up their streets, providing, for example, an exclusive bus/bicycle lane set off from the normal car lane, set off in turn from the sidewalk. In some cities, trolleys, bicycles, taxis, pedestrians, and private cars EACH have separate lanes on the busy streets (see photo top left).

Amsterdam / Edward Bergman



SIDEWALK

CARS

BIKEPATH

TROLLEY-LANE

Middletown, CT / MWJ



Shanghai / Allan Jacobs



Providence, RI / MWJ



CONTENTS

INTRODUCTION	4
AREAS SUBJECT TO REVIEW	5
HISTORIC PRESERVATION	12
MIX OF USES	13
THE STREET	14
CONTEXTUAL DEVELOPMENT	19
URBAN GREENERY	20
UPSTAIRS / DOWNTOWN	21
SIGNAGE	22
APPENDICES	31
A. DRPB ESTABLISHMENT	31
B. HISTORIC SITE ZONING	32
C. VILLAGE DIST. ACT	33
D. VILLAGE DIST. ZONING	35
E. SUMMARY OF DOI GUIDE	38
F. LARGE RETAIL	40
G. PERMIT PROCEDURE	56

GUIDELINES :

The Downtown, Village, and Water-front districts shall be designated "pedestrian districts." The board will remain aware of -- and bring to bear their influence on -- the position of importance that streets have in the scheme of public space in these districts of the city. The development, maintenance, and alteration of streets and sidewalks in pedestrian districts shall occasion the strict oversight and scrutiny of the Board.



design review & preservation board  
*Design Guidelines*

Intersections are the places where the interplay among vehicles and pedestrians is most significant to and demanding of good design. Bump-outs, differentiated paving materials, voice or audio-signals for the blind, bollards, and striping are all methods that can be used to address intersections safely and effectively.

*Primacy of Pedestrians*



Paris / Unknown



Philadelphia / April Saul



Middletown, CT / MWJ

In Middletown's Downtown, Village, and Waterfront districts, design should first and foremost encourage pedestrians. Window shopping, street level entrance and egress, and unobstructed strolling paths should all be encouraged -- not discouraged -- by traffic engineering and the design of proposed construction or renovation projects in the downtown business zones. By reviewing designs in these districts with the objective of cultivating a pedestrian atmosphere, other important public objectives of safety, economic development, and neighborhood sociability are achieved.

*Animate the Street*

Events, activity, and spectacles of almost any kind enliven the street and sidewalk in positive ways. One obvious example of this is the age-old practice of putting tables and chairs outside of restaurants for *al fresco* dining. Sidewalk cafes, when properly arranged, can, through providing the opportunity for both diners and passersby to enjoy the spectacle of the street and each other, enliven and stabilize the street environment.



Copenhagen / Allan Jacobs

G U I D E L I N E S :

Outdoor dining ("sidewalk cafes") shall be encouraged throughout the downtown, waterfront, and village district areas. Placement of tables and chairs on the sidewalks shall leave clear a lane the greater of one third or six (6') feet of the sidewalk width.

design review & preservation board  
*Design Guidelines*

Middletown, CT / MWJ



WHEELCHAIR-ACCESSIBLE RAMP



16

G U I D E L I N E S :

ADA Preferred Design:  
 At-grade (non-ramp) entrance.

*ADA Compliance*

While the city's objectives of good design and diligent preservation are laudable, they will count for little unless -- once achieved -- they benefit *all* Middletown residents. Compliance with the ADA (Americans with Disabilities Act) shall be a concurrent objective of all major construction projects reviewed by the Board.

Middletown, CT / MWJ



As a design principle, the provision of building access to persons who use wheelchairs should not stigmatize or draw unnecessary attention to the disability or the access measures taken to provide for it. Ramps designed to be obtrusive, appendage-like structures, grafted on to the exterior facades of buildings, therefore, are discouraged. New buildings, or projects which are doing extensive work to their exterior facades, are encouraged to build their entrances at-grade, thus providing access equally to those in wheelchairs and those on foot.



Middletown, CT / MWJ

C O N T E N T S

INTRODUCTION	4
AREAS SUBJECT TO REVIEW	5
HISTORIC PRESERVATION	12
MIX OF USES	13
THE STREET	14
CONTEXTUAL DEVELOPMENT	19
URBAN GREENERY	20
UPSTAIRS / DOWNTOWN	21
SIGNAGE	22
APPENDICES	31
A. DRPB ESTABLISHMENT	31
B. HISTORIC SITE ZONING	32
C. VILLAGE DIST. ACT	33
D. VILLAGE DIST. ZONING	35
E. SUMMARY OF DOI GUIDE	38
F. LARGE RETAIL	40
G. PERMIT PROCEDURE	56



design review & preservation board  
*Design Guidelines*

When regrading is not a viable option, the design objective, again, should be to visually de-emphasize the special access measures. Several excellent examples of this are visible in the city's Village District.



Middletown, CT / MWJ

One approach is to address the issue within the structure of the accessibility measure itself such as evidenced in Wesleyan's Human Resources building pictured on the facing page.



Middletown, CT / MWJ

Another approach is to address the issue through landscaping as shown in the pictures on this page.

Finally, as demonstrated by the College Street entrance to Fiske Hall (pictured upper right), when an alternate means of access must be provided, visually blending the conventional and barrier-free access together is recommended.

Handicap-designated parking spaces should be provided with thought given to curb cut locations **and** how the person will get to them from his/her vehicle. Many current spaces force the passenger to wheel into traffic in order to reach the curb cut.



Middletown, CT / MWJ

G U I D E L I N E S :

ADA Alternative Design:

Subtle, naturalistic ramps that utilize landscaping and existing slopes.

design review & preservation board  
*Design Guidelines*

Providence, RI / MWJ



Barcelona / Allan Jacobs



*Public Art*

Throughout history, cities and their more prominent corporate citizens, have used large building projects as opportunities to elevate the public realm. Sculptures, monuments, murals, and gateways are all examples. Many cities have written public art plans and adopted “1%-for-Art” ordinances, setting aside one percent of all capital improvement projects for a public art fund to build monuments, sculptures, murals etc. on public land around the city (See CA Quimby Act and City of Ventura).

*Reduce Visual Impact of Parking*

While clearly necessary for the overall transportation system and access to and around downtown, parking lots and structures can have serious negative visual and environmental effects. Because they are utilitarian elements, parking lots and garages often do not receive the same level of design attention as other types of land uses. While they may not merit the same level of materials and finishes that a major building would, care in the use of basic design elements can make a significant difference. Landscaping, trees, and planters can also mitigate the negative visual effects of parking lots and structures.



18

G U I D E L I N E S :

A minimum thirty (30 ft<sup>2</sup>) square feet of landscaping should be provided for each parking space. Required landscaping should take the form of planter strips, landscaped areas and perimeter landscaping. The landscaping should be dispersed throughout the parking lot, but must also extend along the entire frontage of adjacent streets, except for entry points. Planter strips, landscaped areas, and perimeter landscaped areas should have a minimum width of five (5') feet. Walls, fences, hedges or rows of trees should enclose the lot, maintaining the streetwall.

C O N T E N T S

INTRODUCTION	4
AREAS SUBJECT TO REVIEW	5
HISTORIC PRESERVATION	12
MIX OF USES	13
THE STREET	14
CONTEXTUAL DEVELOPMENT	19
URBAN GREENERY	20
UPSTAIRS / DOWNTOWN	21
SIGNAGE	22
APPENDICES	31
A. DRPB ESTABLISHMENT	31
B. HISTORIC SITE ZONING	32
C. VILLAGE DIST. ACT	33
D. VILLAGE DIST. ZONING	35
E. SUMMARY OF DOI GUIDE	38
F. LARGE RETAIL	40
G. PERMIT PROCEDURE	56



design review & preservation board  
*Design Guidelines*

CONTEXTUAL DEVELOPMENT

*The Streetwall*

An integral feature of many downtowns is the streetwall, or the consistent, unbroken corridor of building facades that runs the length of a downtown street. With a few exceptions, Middletown's Main Street has no major "cavities," a characteristic that should be preserved. There are a few areas where sites of former buildings on Main Street have been filled-in with gardens, parks, or parking lots. Although such land uses are good, suitable uses for the downtown, on Main Street, they fail to serve the function of filling gaps in the streetwall. Wherever possible, the city should encourage proposals that minimize or replace gaps in the streetwall.

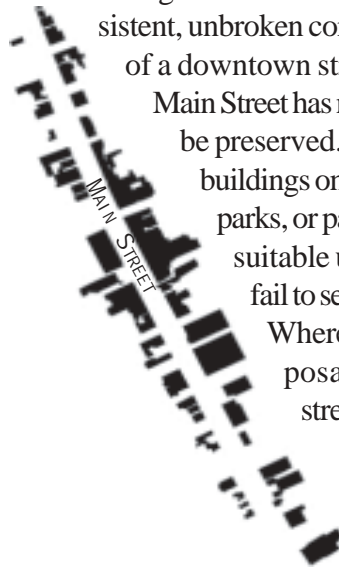

*Sympathetic Infill*

A proposal for a new building in the business zones should be responsive to its context. Compatibilities in size, scale, and style shall be criteria for evaluating proposals for new buildings or significant renovations. The rhythm of voids and solids in the building's facade, i.e. the placement of doors, windows, and fenestration in general, is another consideration. Similarly, for the downtown areas, the impact of a building's proposed facade on the existing patterns of pedestrian activity should be considered.

*Density*

Density alone seldom saves or destroys a neighborhood, but dramatic changes in density can often disrupt a neighborhood's cohesiveness.



Paris / Unknown

G U I D E L I N E S :

Projects affecting structures which contribute to the streetwall shall be required to present for design review a streetwall preservation strategy.

Infill should be compatible with context, as should density. Proposed changes in density should show current and future density (measured in dwelling units / acre), and establish that the changes will not be disruptive to community character.

INTRODUCTION	4
AREAS SUBJECT TO REVIEW	5
HISTORIC PRESERVATION	12
MIX OF USES	13
THE STREET	14
CONTEXTUAL DEVELOPMENT	19
URBAN GREENERY	20
UPSTAIRS / DOWNTOWN	21
SIGNAGE	22
APPENDICES	31
A. DRPB ESTABLISHMENT	31
B. HISTORIC SITE ZONING	32
C. VILLAGE DIST. ACT	33
D. VILLAGE DIST. ZONING	35
E. SUMMARY OF DOI GUIDE	38
F. LARGE RETAIL	40
G. PERMIT PROCEDURE	56

From Bulletin No. 11, Tree City USA, USDA

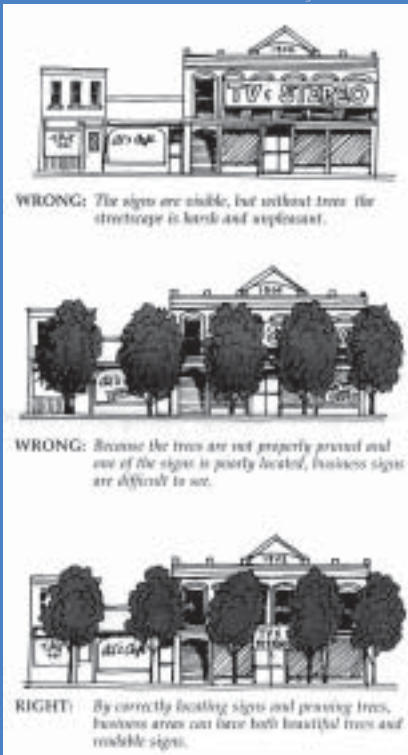

## URBAN GREENERY

### Trees

Trees contribute significantly to the visual qualities of streets and other public open spaces. Studies have also shown them to have a positive effect on retail sales. Finally, they also make measurable contributions to improving environmental conditions by providing shade and wind protection. Trees are however, often difficult to grow successfully in dense urban conditions and should be planted only after determinations are made that adequate sunlight and other microclimatic conditions are suitable. Tree/Sign conflicts must also be anticipated and avoided (see illustration left).



Phi Ladelphi a / MWJ

### Planters

Flower planters -- under windows, draped on streetlamps, on street medians, and on sidewalks -- do much to beautify a business district. Their use is encouraged in the downtown, village, and waterfront districts.



Signs of habitation

Unknown / Allan Jacobs

### General Landscaping

Parking lots, commercial strips, and major streets are typically under-landscaped. Parking lots should incorporate trees, planter strips, and perimeter landscaping to reduce the visual impact of parking lots. Businesses on the city's commercial strips, such as

## G U I D E L I N E S :

Sign placement shall accommodate tree placement and growth. Projects on Routes 66, 3, 17, and 154 shall be strongly encouraged to develop, promote, and maintain landscaping along street edges.



*Design Guidelines*

the Route 66 Corridor, should further landscape areas along the roadside to soften the corridor's edges and make more pleasant these gateways to the city. Main Street's extraordinary width offers a third landscaping opportunity: the placement of a planted median along the street's middle lanes.

## UPSTAIRS / DOWNTOWN

A common characteristic of many under-performing downtowns is a failure to utilize more than the ground floor space of downtown buildings. From a design and preservation perspective, this represents significant opportunity costs and unmet potential.

Balconies, such as those that existed in Middletown's past and continue to exist in historic districts like New Orleans' French Quarter, animate the upper stories of buildings significantly.

Encouraging a mix of uses in the buildings of downtown, as discussed earlier in this document, is another way of repopulating these buildings and the streets on which they front. Office and/or residential tenants on the second, third, and fourth stories above ground floor retail, are feasible options to consider promoting.

Middletown / Greater Middletown Preservation Trust



## G U I D E L I N E S :

The Board shall encourage the development and study of upper-story utilization in the downtown area.



design review & preservation board  
*Design Guidelines*

Middletown, CT / MWJ



RETRACTABLE  
AWNING

MODESTLY SCALED  
AND ACCURATELY-  
PLACED SIGN

SIGNS, STOREFRONT, AND  
SIDEWALK ARE ILLUMI-  
NATED VIA DECORATIVE,  
EXTERNAL FIXTURES.

(NOTE: TREE DOES  
NOT INTERFERE WITH  
SIGHTLINE ON  
SIGNS.)

22

G U I D E L I N E S :

In reviewing sign applications, the Board shall evaluate the proposed sign's architectural context as it relates to scale, placement, color, and illumination. If one business is proposing more than one sign, the review shall exercise greater scrutiny in proportion to the number of signs proposed.

Middletown, CT / MWJ



Middletown, CT / MWJ



SIGNAGE

Signage is a vital element of Middletown's downtown environment, capable of providing scale, color and interest to the streetscape. When a sign is in scale with its architectural surroundings, appropriately placed and well designed, it gives a positive effect to the business, its neighbors and to the whole of downtown. When the streetscape is cluttered with too many poorly designed or poorly placed signs, the resulting visual confusion reduces each sign's effectiveness. Due to the unique qualities of each individual structure in the street area, different signage types will be appropriate according to the character of the building and the tenant's needs. Design criteria for reviewing signage include scale, number, placement, and illumination.

Middletown, CT / MWJ



C O N T E N T S

INTRODUCTION	4
AREAS SUBJECT TO REVIEW	5
HISTORIC PRESERVATION	12
MIX OF USES	13
THE STREET	14
CONTEXTUAL DEVELOPMENT	19
URBAN GREENERY	20
UPSTAIRS / DOWNTOWN	21
SIGNAGE	22
APPENDICES	31
A. DRPB ESTABLISHMENT	31
B. HISTORIC SITE ZONING	32
C. VILLAGE DIST. ACT	33
D. VILLAGE DIST. ZONING	35
E. SUMMARY OF DOI GUIDE	38
F. LARGE RETAIL	40
G. PERMIT PROCEDURE	56



design review & preservation board  
*Design Guidelines*

*Historical Background*

Generally, the form of signage appropriate for an older building will depend upon whether or not it was originally constructed for commercial use. If it was, a signage space is generally provided. During the eighteenth and early nineteenth centuries, signboards mounted on building facades were rare. More common were hanging signs, often colorfully painted and suspended out from the building or on poles nearer the street. Tavern signs are a common example of this type.

In the mid-nineteenth century, signboards became more common as buildings were increasingly designed and erected for commerce. The largely pedestrian street traffic of the era could appreciate the rich ornamentation, careful proportion, and hand-carved lettering that characterized the typical signboard.

Advancing technology and the advent of the automobile in the 20th century led to the production of signs from new materials, and the use of graphic styles designed to quickly catch the motorist's eye and deliver a message. The plastic, backlit sign was a product of this period. The ultimate extension of this signage philosophy was the idea that the entire facade was a signage opportunity, leading to the covering of many richly detailed older buildings to create a neutral background for a store's logo.

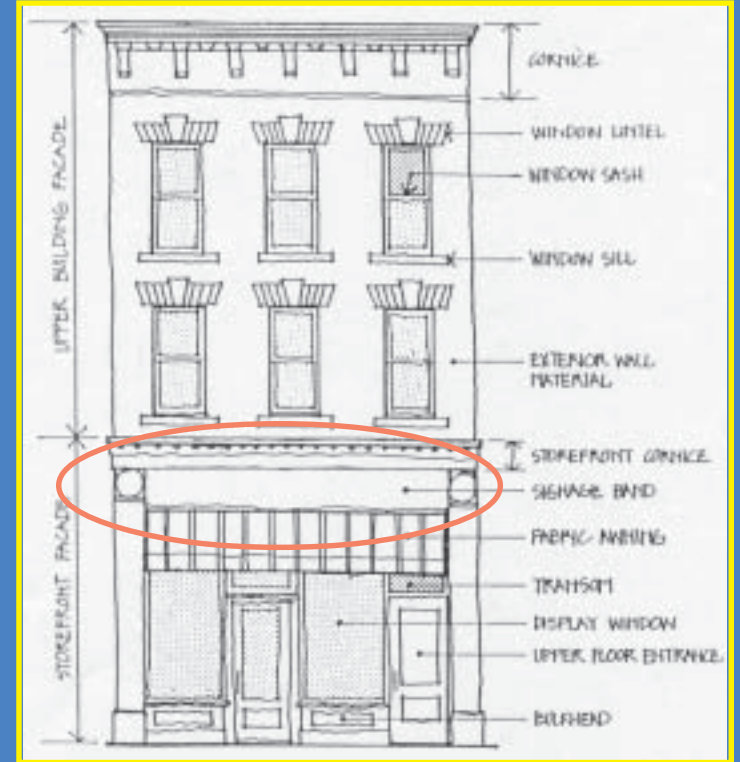

G U I D E L I N E S :

In sign placement, the Board will encourage the use of signage bands on historic storefront buildings. In historic commercial districts, the Board will encourage placement of signs on the storefront of non-historic buildings in locations such that contextual continuity and coherence is preserved and expanded.



24

## GUIDELINES :

Removal of some signs can often improve the visual appearance of a building; these include modern backlit fluorescent signs, large applied signs with distinctive corporate logos, and those signs attached to a building in such a way as to obscure significant architectural detailing. If new signs are designed, they should be of a size and style compatible with the historic building and should not cover or obscure significant architectural features.

Signs were an important aspect of 19th and early 20th century storefronts and today play an important role in defining the character of a business district. In examining historic streetscape photographs, one is struck by the number of signs - in windows, over doors, painted on exterior walls, and hanging over (and sometimes across) the street. While this confusion was part of the character of 19th century cities and towns, today's approach toward signs in historic districts tends to be much more conservative.

For many 19th century buildings, it was common to mount signs on the lintel above the first story. Another common approach, especially at the turn of the century, was to paint signs directly on the inside of the display windows. Frequently this was done in gold leaf. New hanging signs may be appropriate for historic commercial buildings, if they are of a scale and design compatible with the historic buildings. Retention of signs and advertising painted on historic walls, if of historic or artistic interest (especially where they provide evidence of early or original occupants), is encouraged.

## CONTENTS

INTRODUCTION	4
AREAS SUBJECT TO REVIEW	5
HISTORIC PRESERVATION	12
MIX OF USES	13
THE STREET	14
CONTEXTUAL DEVELOPMENT	19
URBAN GREENERY	20
UPSTAIRS / DOWNTOWN	21
SIGNAGE	22
APPENDICES	31
A. DRPB ESTABLISHMENT	31
B. HISTORIC SITE ZONING	32
C. VILLAGE DIST. ACT	33
D. VILLAGE DIST. ZONING	35
E. SUMMARY OF DOI GUIDE	38
F. LARGE RETAIL	40
G. PERMIT PROCEDURE	56





design review & preservation board  
**Design Guidelines**

Definitions and Typology

1. Hanging Bracket



Also known as a “projecting sign,” or a “flag sign,” sign board is hung from a bracket device projecting from the building wall at a 90-degree angle.

Hanging bracket signs work well for distant viewing from approaching pedestrians as well as vehicular passengers, and are encouraged by the Board. Currently, a city ordinance requires posting a bond with the Building Division before a permit for hanging bracket signs is granted.

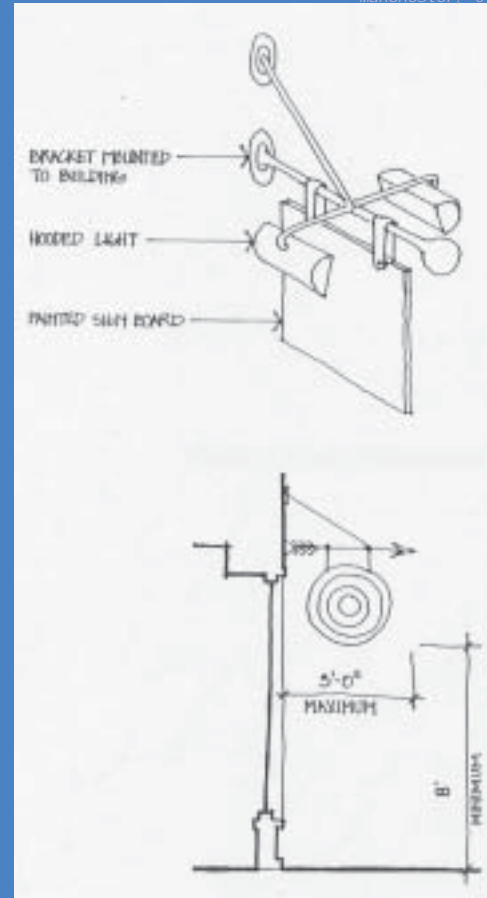

G U I D E L I N E S :

Requirements for Hanging Bracket signs include the following.

- Posting of a bond
- Fasten bracket mounts to joints, not masonry itself
- Sign to be finished on both sides and be a rigid and opaque material
- Minimum vertical clearance below of 8' feet
- Maximum lateral extension from building facade of 3' feet
- If illuminated, a hooded incandescent light fixture

Northampton, MA / MWJ



## 2. Surface Mounted Sign



A sign fastened, placed, or painted on a wall, window, cupola, or parapet of a building or structure, in such a manner that only one side of the sign is visible.

This sign is used for viewing at a distance, from across the street or from the vehicular passengers driving by. It should be placed below the storefront cornice and in such a way that avoids visual conflicts

with nearby trees (see page 12). The sign's width should not exceed that of the storefront.

Individual letters and/or logos or a signboard may be mounted directly on the building facade. The sign should be mechanically fastened at the mortar joints and not into the brick or stone.

If the sign is to be illuminated, external illumination with hooded incandescent light fixtures should be used. ***Internally lit sign boxes should be avoided whenever possible*** - but if used - the background should not be painted white; choosing another color for the background (so only the letters appear lit) is encouraged.

26

### GUIDELINES:

- Surface mounted signs shall:
- be placed below the storefront cornice
  - not conflict with tree placement
  - be of a width approximate to that of the storefront
  - be fastened at the building's mortar joints, not in the masonry itself
  - be externally illuminated, especially in the downtown, village, and waterfront districts

### CONTENTS

INTRODUCTION	4
AREAS SUBJECT TO REVIEW	5
HISTORIC PRESERVATION	12
MIX OF USES	13
THE STREET	14
CONTEXTUAL DEVELOPMENT	19
URBAN GREENERY	20
UPSTAIRS / DOWNTOWN	21
SIGNAGE	22
APPENDICES	31
A. DRPB ESTABLISHMENT	31
B. HISTORIC SITE ZONING	32
C. VILLAGE DIST. ACT	33
D. VILLAGE DIST. ZONING	35
E. SUMMARY OF DOI GUIDE	38
F. LARGE RETAIL	40
G. PERMIT PROCEDURE	56



design review & preservation board  
*Design Guidelines*

3. Painted on Glass Sign



*A sign whose lettering and/or graphics is applied on the surface of the business's window by means of hand painting, silk screening, or frisket cutting and spraying.*

This sign should be scaled to the pedestrian and should be located in the display window or on the entrance door glazing. This technique is also traditionally used for applying the street address number on the entrance door transom. The maximum letter height should not exceed eight (8") inches.

4. Internally Mounted Neon; Restaurant Menu Signs



*A neon sign, mounted on the building's interior; a restaurant's menu, displayed on an easel or other stand, and visible through the storefront window.*

Neon can be a colorful and lively addition to any storefront as long as it is used in moderation.

Restaurants may display a copy of their actual printed menu by mounting it in a wood or metal frame covered with glass. A framed chalk board may also be displayed to announce any special menu items.

G U I D E L I N E S :

Neon signs shall be placed at storefront level, with type size not to exceed 1' foot in height. They shall be hung from a skeleton frame and set slightly back from storefront window.

## CONTENTS

INTRODUCTION	4
AREAS SUBJECT TO REVIEW	5
HISTORIC PRESERVATION	12
MIX OF USES	13
THE STREET	14
CONTEXTUAL DEVELOPMENT	19
URBAN GREENERY	20
UPSTAIRS / DOWNTOWN	21
SIGNAGE	22
APPENDICES	31
A. DRPB ESTABLISHMENT	31
B. HISTORIC SITE ZONING	32
C. VILLAGE DIST. ACT	33
D. VILLAGE DIST. ZONING	35
E. SUMMARY OF DOI GUIDE	38
F. LARGE RETAIL	40
G. PERMIT PROCEDURE	56

## 6. Freestanding Signs



Unknown

A sign supported by upright(s), brace(s), pole(s), post(s), or pylon(s), placed at or near ground level, or resting upon a foundation on the ground, and which is not attached to any building.

Road signs whose message specifically targets motorists are placed more closely to the road and are often freestanding. This is particularly true for signs in the Route 3 (Newfield Street),

Route 17 (South Main Street), Route 66 (Washington Street), and Route 154 (Old Saybrook Rd.) corridors.

## 7. Miscellaneous Other Signs

Flyers, posters, and spontaneously affixed advertisements are generally allowed in obvious, designated locations (such as kiosks), but should never be nailed into trees. Sandwich board signs may be worn by a person in the employ of the business being advertised, or by a person advertising their own business. Such “walking” signs are not only effective and eye-catching, but animate the sidewalk. Sandwich boards which are haphazardly left on the street clutter the sidewalk and may create a stumbling hazard. When used, they should be of a weight that will withstand typical wind speeds for Middletown. Banners, so long as their use is not overextended, can create a festive, colorful effect for a business, and for its street. Fabric banners, properly fastened or mounted, are encouraged, either as temporary substitutes for -- or supplemental to -- permanent signs of the types discussed above.



Essex, CT / MWJ



Killingworth, CT / MWJ

### GUIDELINES:

Freestanding signs emphasizing simplicity, in design, color, and verbiage, shall be encouraged. Monolith-style road signs and exterior-lit, wooden, carved signs of appropriate scale shall be permitted. Where signs advertise more than one business, a coherence or coordination of style within the sign is required. Landscaping treatment at the sign's base is encouraged. Applicants for these signs are also encouraged to consider external illumination, be it footlights, lights attached to the sign itself, or to the sign support.



design review & preservation board  
*Design Guidelines*

8. Awnings and Canopies

*An architectural projection that provides weather protection, identity, or decoration and is supported partially by two or more stanchions and/or wholly by the building to which it the awning / canopy is attached.*

Storefront awnings and canopies are both functional and decorative -  
 - functional because they provide sun protection for the merchandise, rain and snow protection for shoppers, and signage for the business. They bring a decorative element to the streetscape with color, pattern and/or graphics. Genuine retractable awnings are encouraged by the Board.

9. Signs Located above the First Floor

*Signs for businesses which are not located on the street level.*

Businesses located in the upper stories of buildings with other ground floor businesses often advertise with stenciled signs in their windows, and/or with a ground floor directory, either outside or just inside the entrance. Examples of upper story awnings in other downtowns, as well as in historical Middletown photos show them to be another viable method of drawing attention to businesses above the ground floor.

CONCLUSION

Design -- as well as the laws, attitudes, and perceptions that influence it -- changes. So too will these guidelines. If you are an applicant, or a contractor / consultant working on behalf of an applicant, and referring to these guidelines in preparation of a project submission or a

Middletown / Greater Middletown Preservation Trust



Middletown / MWJ



G U I D E L I N E S :

Historically, fabric retractable awnings were used and this continues to be the preferred awning type. Stationary, non-retractable awnings should not be used. The color or stripe chosen for the awning should complement the general color scheme of the building. Verbiage printed on the awning should be limited to the street address of the store. The width of the awning or canopy should not exceed the width of the storefront.

Northampton, MA / MWJ



30

## G U I D E L I N E S :

Businesses in the downtown which are above the ground floor may use painted-on glass signs (see page 19), awnings, and/or ground floor directories to direct customers to their location. Surface-mounted signs placed on upper stories shall be discouraged.

legal action, please consult with the Department of Planning, Conservation, and Development to make sure that the edition you are using is up-to-date. Also, applicants, contractors, and consultants -- as well as members of the community interested in design and preservation issues and members of the public at large -- are welcome to contact the Department with comments or suggestions on revising this document for its next edition.

Questions, comments, and concerns can be addressed to:

Munro W. Johnson, Community Development Specialist  
(860) 344-3425 | [munro.johnson@cityofmiddletown.com](mailto:munro.johnson@cityofmiddletown.com)

## C O N T E N T S

INTRODUCTION	4
AREAS SUBJECT TO REVIEW	5
HISTORIC PRESERVATION	12
MIX OF USES	13
THE STREET	14
CONTEXTUAL DEVELOPMENT	19
URBAN GREENERY	20
UPSTAIRS / DOWNTOWN	21
SIGNAGE	22
APPENDICES	31
A. DRPB ESTABLISHMENT	31
B. HISTORIC SITE ZONING	32
C. VILLAGE DIST. ACT	33
D. VILLAGE DIST. ZONING	35
E. SUMMARY OF DOI GUIDE	38
F. LARGE RETAIL	40
G. PERMIT PROCEDURE	56



APPENDICES

*Appendix A: Middletown Code of Ordinances, Chapter 26-10*

Sec. 26-10. Middletown Design Review and Preservation Board.

There shall be an advisory board known as the Design Review and Preservation Board, which shall consist of nine (9) members. Of the members appointed, three (3) shall serve until June 30, 1996; three (3) shall serve until June 30, 1997; and three (3) shall serve until June 30, 1998. Thereafter, appointments shall be for a term of three (3) years. The Board shall include membership from the Greater Middletown Preservation Trust, the Middletown Special Services district or comparable agency, and the public at large. Its membership should include expertise in architecture, planning, historic preservation and urban design. The Board shall create guidelines for; and, when requested, shall review designs for exterior rehabilitation or new construction in business zones, including signage; and advise the Planning and Zoning Commission and the Redevelopment Agency regarding their appropriateness. The Board shall be the recipient and keeper of historic easements held by the City. It shall further, provide a forum for, and advise the Economic Development Committee on the demolition of any structure in the historic districts, or any structure listed in Middletown's Historic Resources Inventory, the National or State Registers of Historic Places, or the Inventory of Historic Engineering and Industrial Sites. The Board shall also perform such duties as are required and permitted of a municipal preservation board by the General Statutes and shall make recommendations to the Mayor and Common Council concerning any issue related to the preservation of architectural and historically significant artifacts, buildings and streetscapes.

(6/5/95)

Middletown, CT



State Statutes Governing Historic Districts

Middletown has seven (7) registered Historic Districts, five (5) of which are located in business zones and subject to design review.







32

Title 7, Chapter 97a, Section 7-147 of the Connecticut General Statutes sets out the rules governing historic districts, commissions, and properties.

The Connecticut General Statutes are available in the Department of Planning, Conservation, & Development, the Russell Library, and searchable online, at <http://prdbasis.cga.state.ct.us/BASIS/TSAMDHP/LIN1/AMD/MSF> (search for "7-147" under "Statutes K").

**Downtown Historic Districts**

- Historic Districts**
-  **Broad Street**
  -  **Main Street**
  -  **Metro South**
  -  **South Green**
  -  **Washington St.**

*Appendix B: City of Middletown Zoning Code*

44.08.26 HISTORIC AND/OR ARCHITECTURAL PRESERVATION SITE AND STRUCTURES (page 90)

- A. The site, building or structure proposed shall be included in the Middletown Survey of Historical and Architectural Resources conducted by the Greater Middletown Preservation Trust, dated 1979, as either inventoried or notable buildings. (Effective 8/1/84.) Other buildings and structures may apply under this section provided that it is determined by the Greater Middletown Preservation Trust, or another qualified professional selected by the Commission, that the building meets the survey criteria and that the proposed reuse is compatible with the historic character and fabric of the building. (Amended effective 10/15/90)
- B. Permitted use of a site and structure shall be harmonious with the physical characteristics and originally designed use of the structure: i.e. a structure designed for a residence may be used as an office.
- C. A written agreement shall be filed with the Commission stipulating that the exterior of the structure and the site will be restored and maintained in accordance with the historic time period the structure is identified.
- D. In the event the proposed historic preservation structure is located in a fire district with which its materials of construction are incompatible, application, via the Commission, shall be made to the legislative body to change the boundaries of the fire district so that the Historic Preservation Zone is designated outside fire limits in terms of the State Building Code. The proposed Historic Preservation structure shall not be less than thirty (30') feet from any structure in a contiguous fire district.
- E. Off-street parking requirements for architecturally and historically significant buildings with adaptive uses may be modified when a proponent can show (a) needed off-street parking is or could be available in the vicinity and; (b) the economic feasibility of the project depends on the waiving of some or all of the off-street parking requirements.
- F. All proposals under this category shall submit a narrative, and for major projects architectural renderings, explaining how the applicant intends to renovate and preserve the historic facade and overall historic character of the building. All proposals may be referred to the Middletown Preservation Board for review and comment. The Preservation Board's comments shall be purely advisory. (Added effective 10/23/91)

**CONTENTS**

INTRODUCTION	4
AREAS SUBJECT TO REVIEW	5
HISTORIC PRESERVATION	12
MIX OF USES	13
THE STREET	14
CONTEXTUAL DEVELOPMENT	19
URBAN GREENERY	20
UPSTAIRS / DOWNTOWN	21
SIGNAGE	22
APPENDICES	31
A. DRPB ESTABLISHMENT	31
B. HISTORIC SITE ZONING	32
C. VILLAGE DIST. ACT	33
D. VILLAGE DIST. ZONING	35
E. SUMMARY OF DOI GUIDE	38
F. LARGE RETAIL	40
G. PERMIT PROCEDURE	56



*Appendix C: State of Connecticut Village Districts*

1998PA-00116.PA;2 Public Act 2 of 3  
Connecticut General Assembly  
Public Act 2 of 3  
Number: 116

Year: 1998  
Name: 1998PA-00116.PA;2

Substitute House Bill No. 5485  
Substitute House Bill No. 5485

PUBLIC ACT NO. 98-116

AN ACT AUTHORIZING THE ESTABLISHMENT OF VILLAGE DISTRICTS.

Be it enacted by the Senate and House of Representatives in General Assembly convened: (NEW) (a) The zoning commission of each municipality may establish village districts as part of the zoning regulations adopted under section 8-2 of the general statutes, as amended. The regulations establishing village districts shall protect the distinctive character, landscape and historic structures of such areas and may regulate, on and after the effective date of such regulations, (1) alterations and improvements in such areas and (2) substantial reconstruction and rehabilitation of properties within the district and in view of public roadways, including, but not limited to, (A) the design and placement of buildings, (B) the maintenance of public views, (C) the design, paving materials and placement of public roadways and (D) other elements that the commission deems appropriate to maintain and protect the character of the village district. In adopting the regulations, the commission shall consider the design, relationship and compatibility of structures, planting, signs, roadways, street hardware and other objects in public view. Such regulations shall encourage the conversion and preservation of existing buildings and sights in a manner that maintains the historic, natural and community character of the district. The regulations concerning the exterior of structures or sites shall be consistent with the "Connecticut Historical Commission -The Secretary of the Interior's Standards for Rehabilitation and Guidelines for Rehabilitating Historic Buildings", revised through 1990, as amended. The regulations shall provide (i) that proposed buildings or modifications to existing buildings be harmoniously related to their surroundings, to the terrain and to the use, scale and architecture of existing buildings in the vicinity that have a functional or visual relationship to a proposed building or modification, (ii) that all spaces and structures visible to the public from public roadways be designed to add to the visual amenities of the area consistent with those of the village district in and around the proposed building or modification, (iii) that the color, size, height, proportion of openings, roof treatments, building materials and landscaping of commercial or residential property and any proposed signs and lighting be evaluated for compatibility with the local architectural motif and the maintenance of

Middletown's Downtown Village District



views, historic buildings, monuments and landscaping, and (iv) that the removal or disruption of historic traditional or significant structures or architectural elements shall be minimized. (b) All development in the village district shall be designed to achieve the following compatibility objectives with other uses within the immediate neighborhood of the proposed development: (1) The arrangement and orientation of any proposed building or site improvement shall be similar in the immediate neighborhood; (2) the building and layout of buildings and parking lots shall reinforce existing buildings and streetscape patterns and the placement of buildings and parking lots shall assure there is no adverse impact on the immediate neighborhood; (3) proposed streets shall be connected to the existing neighborhood road network, wherever possible; (4) open spaces of the proposed development shall reinforce open space patterns of the immediate neighborhood, in form and siting; (5) locally significant features of the site such as distinctive buildings or vistas, shall be integrated into the site design; (6) the landscape design shall complement the neighborhood's landscape patterns and reinforce functional qualities; (7) the exterior signs, site lighting and accessory structures shall support a uniform architectural theme and present a harmonious relationship with the surrounding neighborhood; and (8) the scale, proportions, massing and detailing of the proposed building shall be in proportion to the scale, proportion, massing and detailing in the neighborhood. (c) All applications for new construction and substantial reconstruction within the district and in view from public roadways shall be subject to review and recommendation by an architect or architectural firm selected and contracted by the commission and designated as the village district architectural consultant for such application. The village district architectural consultant shall review an application and report to the commission within thirty-five days of receipt of the application. The report and recommendation of the village district architectural consultant shall be entered into the public hearing record and considered by the commission in making their decision. Failure of the village district architectural consultant to report within the specified time shall not alter or delay any other time limit imposed by the regulations. The commission may seek the recommendations of any town or regional agency or outside specialist with which it consults, including, but not limited to, the municipality's historical society, the Connecticut Trust for Historic Preservation and The University of Connecticut College of Agriculture and Natural Resources. Any reports or recommendations from such agencies or organizations shall be entered into the public hearing record. (d) No decision of a commission under this section shall be effective until a copy thereof, certified by the commission, containing the name of the owner of record, a description of the premises to which it relates and specifying the reasons for its decision, is recorded in the land records of the town in which such premises are located. The town clerk shall index the same in the grantor's index under the name of the then record owner and the record owner shall pay for such recording. (e) As used in this section "neighborhood" means the existing buildings and land uses adjacent to and extending from a proposed development to a definable boundary such as a primary collector or arterial boundary, a significant change in character or land use or a major natural feature.

**C O N T E N T S**

INTRODUCTION 4

AREAS SUBJECT TO REVIEW 5

HISTORIC PRESERVATION 12

MIX OF USES 13

THE STREET 14

CONTEXTUAL DEVELOPMENT 19

URBAN GREENERY 20

UPSTAIRS / DOWNTOWN 21

SIGNAGE 22

APPENDICES 31

A. DRPB ESTABLISHMENT 31

B. HISTORIC SITE ZONING 32

C. VILLAGE DIST. ACT 33

D. VILLAGE DIST. ZONING 35

E. SUMMARY OF DOI GUIDE 38

F. LARGE RETAIL 40

G. PERMIT PROCEDURE 56



Approved May 22, 1998

*Appendix D: Zoning for Middletown's Village District*

SECTION 39D DOWNTOWN VILLAGE DISTRICT (DVD)

39D.01 AUTHORITY

This regulation is adopted pursuant to Public Act 98-116, as amended, an Act Concerning Village Districts, and is authorized by Section 8-2 of the Connecticut General Statutes.

39D.02 PURPOSE

The purpose of this regulation is to protect the distinctive character, landscape, and historic structures within said district.

It is the intent of this regulation to encourage the conversion, conservation and preservation of existing buildings and sites in a manner that maintains the historic and/or unique character of the district and to promote traditional neighborhood design for new construction to ensure compatibility.

39D.03 APPLICABILITY

These regulations shall pertain to:

New construction and substantial, as determined by staff, reconstruction and rehabilitation of properties within the district and in view from public roadways including but not limited to:

- a. the design and placement of buildings;
- b. the design, paving materials and placement of public roadways; and
- c. other elements that the Approving Authority staff deems appropriate to maintain and protect the character of the DVD.

39D.04 REVIEW

Applications for permitted uses shall be treated as a Section 55 Category 3 Site Plan Review. Applications for Special Exception uses shall be treated in accordance with Section 44 of the Zoning Code and Section 8-2 of the Connecticut General Statutes. Only construction expanding the existing footprint by more than twenty percent (20%) shall require the submission of an A-2 survey.



- 39D.05      ADVISORY OPINION  
 All applications for construction and substantial reconstruction within the district and in view from the public roadway shall be subject to an advisory review and recommendation by the Middletown Design Review Preservation Board. The report and recommendation shall be entered into the public record and considered in the decision. The Approving Authority may seek other reports and recommendations in accordance with Section 55 of this Code.
- 39D.06      APPROVAL  
 The Approving Authority shall state on the record the reasons for any decision and if the Approving Authority denies an application, it shall cite the specific regulations under which the application was denied.
- 39D.07      EFFECTIVE DATE  
 No decision shall be effective until a copy thereof, certified by the Chairman, containing the name of the owner of record, a description of the premises to which it relates and specifying the reasons for its decision is recorded on the land records.
- 39D.08      CRITERIA FOR DETERMINATION  
 The Approving Authority shall consider the design, relationship and compatibility of structures, plantings, signs, roadways, street hardware and other objects in public view.
- The Approving Authority shall follow the “Connecticut Historical Commission – The Secretary of the Interims Standards for Rehabilitation and Guidelines for Rehabilitating Historic Buildings” and the following:
- Criteria**
- Applications shall demonstrate the following: (a) that proposed buildings or modifications to existing buildings are harmoniously related to their surroundings, to the terrain and to the use, scale and architecture of existing buildings in the vicinity that have a functional or visual relationship to a proposed building or modification, (b) that all spaces and structures visible to the public from public roadways are designed to add to the visual amenities of the area consistent with those of the village district in and around the

**C O N T E N T S**

INTRODUCTION 4

AREAS SUBJECT TO REVIEW 5

HISTORIC PRESERVATION 12

MIX OF USES 13

THE STREET 14

CONTEXTUAL DEVELOPMENT 19

URBAN GREENERY 20

UPSTAIRS / DOWNTOWN 21

SIGNAGE 22

APPENDICES 31

A. DRPB ESTABLISHMENT 31

B. HISTORIC SITE ZONING 32

C. VILLAGE DIST. ACT 33

D. VILLAGE DIST. ZONING 35

E. SUMMARY OF DOI GUIDE 38

F. LARGE RETAIL 40

G. PERMIT PROCEDURE 56



proposed building or modification, (c) that the color, size, height, proportion of openings, roof treatments, building materials and landscaping of commercial or residential property and any proposed signs and lighting be evaluated for compatibility with the local architectural motif and the maintenance of views, historic buildings, monuments and landscaping, and (d) that the removal or disruption of historic traditional or significant structures or architectural elements are minimized.

All development in the village district shall be designed to achieve the following compatibility objectives: (1) the building and layout of buildings and included site improvements shall reinforce existing buildings and streetscape patterns and the placement of buildings and included site improvements shall assure there is no adverse impact on the district; (2) proposed streets shall be connected to the existing district road network, wherever possible; (3) open spaces within the proposed development shall reinforce open space patterns of the district in form and siting; (4) locally significant features of the site such as distinctive buildings or vistas shall be integrated into the site design; (5) the landscape design shall

complement the district's landscape patterns; (6) the exterior signs, site lighting and accessory structures shall support a uniform architectural theme if a theme exists and be compatible with their surroundings; and (7) the scale, proportions, massing and detailing of any proposed building shall be in proportion to the scale, proportion, massing and detailing in the district.

Use

Uses within the DVD shall be limited to one and two family homes. Churches, daycare centers and public libraries are permitted by Special Exception.

**Lot Size, Setbacks, Lot Coverage**

No minimum lot area or frontage required. Yard requirement is that any building shall have yards sufficient to insure proper design and placement of buildings as determined in the site plan review process and shall generally adhere to the setbacks of surrounding properties which are in keeping with the historic layout of the neighborhood.

**Height**

The maximum height in the DVD zone shall not exceed three (3) stories or thirty-six (36) feet.

(Section adopted effective 10/15/99)



*Appendix E: Summary of The Secretary of the Interior’s Standards for the Treatment of Historic Properties, with Guidelines for Preserving, Rehabilitating, Restoring, & Reconstructing Historic Buildings*

Originally published in 1977, and revised in 1990, the Standards for Rehabilitation of Historic Buildings, established by the Secretary of the Interior, represent our country’s first principles of historic preservation. They were considered in drafting Middletown’s design guidelines. The standards, summarized below, were drawn up by the federal government with an eye to balancing the protection of a building’s historic features with consideration for its economic viability and efficient contemporary use. They are included for those who want to know more about national standards for historic preservation, and for building owners who elect to rehabilitate their historic building in a manner qualifying for federal investment tax credits. Their inclusion here is not intended to serve any regulatory function in Middletown’s downtown area. Complete texts of the Standards are available at Middletown’s Department of Planning, Conservation and Development, and are available online at [www2.cr.nps.gov/tps/standards/index.htm](http://www2.cr.nps.gov/tps/standards/index.htm)

A general outline of the Standards follows:

1. A property shall be used for its historic purpose or be placed in a new use that requires minimal change to the defining characteristics of the building and its site and environment.
2. The historic character of a property shall be retained and preserved. The removal of historic materials or alteration of features and spaces that characterize a property shall be avoided.
3. Each property shall be recognized as a physical record of its time, place, and use. Changes that create a false sense of historical development, such as adding conjectural features or architectural elements from other buildings, shall not be undertaken.
4. Most properties change over time; those changes that have acquired historic significance in their own right shall be retained and preserved.
5. Distinctive features, finishes, and construction techniques or examples of craftsmanship that characterize a property shall be preserved.
6. Deteriorated historic features shall be repaired rather than replaced. Where the

**C O N T E N T S**

INTRODUCTION 4

AREAS SUBJECT TO REVIEW 5

HISTORIC PRESERVATION 12

MIX OF USES 13

THE STREET 14

CONTEXTUAL DEVELOPMENT 19

URBAN GREENERY 20

UPSTAIRS / DOWNTOWN 21

SIGNAGE 22

APPENDICES 31

A. DRPB ESTABLISHMENT 31

B. HISTORIC SITE ZONING 32

C. VILLAGE DIST. ACT 33

D. VILLAGE DIST. ZONING 35

E. SUMMARY OF DOI GUIDE 38

F. LARGE RETAIL 40

G. PERMIT PROCEDURE 56

severity of deterioration requires replacement of a distinctive feature, the new feature shall match the old in design, color, texture, and other visual qualities and, where possible, materials. Replacement of missing features shall be substantiated by documentary, physical, or pictorial evidence.

7. Chemical or physical treatments, such as sandblasting, that cause damage to historic materials shall not be used. The surface cleaning of structures, if appropriate, shall be undertaken using the gentlest means possible.
8. Significant archaeological resources affected by a project shall be protected and preserved. If such resources must be disturbed, mitigation measures shall be undertaken.
9. New additions, exterior alterations, or related new construction shall not destroy historic materials that characterize the property. The new work shall be differentiated from the old and shall be compatible with massing, size, scale, and architectural features to protect the historic integrity of the property and its environment.
10. New additions and adjacent or related new construction shall be undertaken in such a manner that, if removed in the future, the essential form and integrity of the historic property and its environment would be unimpaired.



*Appendix F. Guidelines for Large Retail Establishments*

DESIGN STANDARDS AND GUIDELINES FOR LARGE RETAIL ESTABLISHMENTS

INTRODUCTION

These standards and guidelines are a response to dissatisfaction with corporate chain marketing strategy dictating design that is indifferent to local identity and interests. The main goal is to encourage development that contributes to Middletown as a unique place by reflecting its physical character and adding to it in appropriate ways.

Large retail developments depend on high visibility from major public streets. In turn, their design determines much of the character and attractiveness of major streetscapes in the city. The marketing interests of many corporations, even strong image-making design by professional designers, can be potentially detrimental to community aspirations and sense of place when they result in massive individual developments that do not contribute to or integrate with the city in a positive way.

Middletown already has a development review system that promotes solutions to these general issues. The purpose of these standards and guidelines is to augment those existing criteria with more specific interpretations that apply to the design of large retail store developments.

These standards and guidelines require a basic level of architectural variety, compatible scale, pedestrian and bicycle access, and mitigation of negative impacts. The standards are by no means intended to limit creativity; it is the City's hope that they will serve

APPENDIX F IS ADAPTED FROM A DOCUMENT BY THE SAME NAME OF THE CITY OF FORT COLLINS, CO.

CONTENTS

INTRODUCTION	4
AREAS SUBJECT TO REVIEW	5
HISTORIC PRESERVATION	12
MIX OF USES	13
THE STREET	14
CONTEXTUAL DEVELOPMENT	19
URBAN GREENERY	20
UPSTAIRS / DOWNTOWN	21
SIGNAGE	22
APPENDICES	31
A. DRPB ESTABLISHMENT	31
B. HISTORIC SITE ZONING	32
C. VILLAGE DIST. ACT	33
D. VILLAGE DIST. ZONING	35
E. SUMMARY OF DOI GUIDE	38
F. LARGE RETAIL	40
G. PERMIT PROCEDURE	56





as a useful tool for design professionals engaged in site-specific design in context. They are placed within the framework of the city's Ordinances, Zoning Code, and the City of Middletown's Design Guidelines, all which provide for variance from the requirements if the proposal is equal to or better than the City requirements.

#### PROCEDURE

The following standards and guidelines are intended to be used as design aid by developers proposing large retail developments in community regional shopping centers or as use-by-right; and as an evaluation tool by the City staff, the Design Review and Preservation Board, and the Planning and Zoning Commission in their review processes. These standards and guidelines apply to all projects, which are proposed in the business zones and to all projects for retail establishments of more than 25,000 square feet as use-by-right. "Standards" denoted by (+) are mandatory; "Guidelines" denoted by (o) are not mandatory, but are provided in order to educate planners, design consultants, developers and City staff about the design objectives.

The Planning and Zoning Commission is empowered to overlook the mandatory (+) standards under the following circumstances:

1. The strict application of the standard would result in peculiar and exceptional practical difficulties or exceptional and undue hardship upon the owner of the affected property; or
2. The alternative site planning and building design approach meets the design objectives as stated in the standard, equally well or



better than would compliance with the standard; and

3. In either of the foregoing circumstances, the variance may be granted without substantial detriment to the public good.

**PART I. AESTHETIC CHARACTER**

**1. Facades and Exterior Walls:**

**GUIDELINE:** Facades should be articulated to reduce the massive scale and the uniform, impersonal appearances of large retail buildings and provide visual interest that will be consistent with the community’s identity character, and scale. The intent is to encourage a more human scale that Middletown residents will be able to identify with their community. (o)

**STANDARD: (+)**

- a. Facades greater than 100 feet in length, measured horizontally, shall incorporate wall plane projections or recesses having a depth of at least 3% of the length of the façade and extending at least 20% of the length of the façade. No uninterrupted length of any façade shall exceed 100 horizontal feet.
- b. Ground floor facades that face public streets shall have arcades, display windows, entry areas, awnings, or other such features along no less than 60% of their horizontal length.

**2. Smaller Retail Stores**

**GUIDELINE:** The presence of smaller retail stores gives a center

**C O N T E N T S**

INTRODUCTION 4

AREAS SUBJECT TO REVIEW 5

HISTORIC PRESERVATION 12

MIX OF USES 13

THE STREET 14

CONTEXTUAL DEVELOPMENT 19

URBAN GREENERY 20

UPSTAIRS / DOWNTOWN 21

SIGNAGE 22

APPENDICES 31

A. DRPB ESTABLISHMENT 31

B. HISTORIC SITE ZONING 32

C. VILLAGE DIST. ACT 33

D. VILLAGE DIST. ZONING 35

E. SUMMARY OF DOI GUIDE 38

F. LARGE RETAIL 40

G. PERMIT PROCEDURE 56

a “friendlier” appearance by creating variety, breaking up large expanses, and expanding the range of the site’s activities. Windows and window displays of such stores should be used to contribute to the visual interest of exterior facades. The standards presented in this section are directed toward those situations where additional, smaller stores, with separate, exterior customer entrances are located in the principal buildings. (o)

**STANDARD: (+)**

Where principal buildings contain additional, separately owned stores, which occupy less than twenty five thousand (25,000) square feet of gross floor area, with separate, exterior customer entrances:

- a. The street level façade of such stores shall be transparent between the height of three feet and eight feet above the walkway grade for no less than 60% of the horizontal length of the building façade of such additional stores.
- b. Windows shall be recessed and should include visually prominent sills, shutters, or other such forms of framing.

**3. Detail features**

**GUIDELINE:** Buildings should have architectural features and patterns that provide visual interests, at the scale of the pedestrian, reduce massive aesthetic effects, and recognize local character. The elements in the following standard should be integral parts of the building fabric, and not superficially applied trim or graphics, or paint. (o)



**STANDARD: (+)**

Building facades must include a repeating pattern that shall include no less than three of the elements listed below. At least one of these elements shall repeat horizontally. All elements shall repeat at intervals of no more than thirty (30) feet, either horizontally or vertically.

- Color change
- Texture change
- Material module change
- Expression of architectural or structural bay through a change in plan no less than 12 inches in width, such as an offset, reveal, or projecting rib

**4. Roofs:**

**GUIDELINE:** Variations in rooflines should be used to add interest to, and reduce the massive scale of large buildings. Roof features should compliment the character of adjoining neighborhoods. (o)

**STANDARD: (+)**

Roofs shall have no less than two of the following features:

a. Parapets concealing flat roofs and rooftop equipment such as HVAC units from public view. The average height of such parapets shall not exceed 15% of the height of the supporting wall and such parapets shall not at any point exceed one-third of the height of the supporting wall. Such parapets shall feature three dimensional cornice treatment.

b. Overhanging eaves, extending no less than 3 feet past the supporting walls.

**C O N T E N T S**

INTRODUCTION	4
AREAS SUBJECT TO REVIEW	5
HISTORIC PRESERVATION	12
MIX OF USES	13
THE STREET	14
CONTEXTUAL DEVELOPMENT	19
URBAN GREENERY	20
UPSTAIRS / DOWNTOWN	21
SIGNAGE	22
APPENDICES	31
A. DRPB ESTABLISHMENT	31
B. HISTORIC SITE ZONING	32
C. VILLAGE DIST. ACT	33
D. VILLAGE DIST. ZONING	35
E. SUMMARY OF DOI GUIDE	38
F. LARGE RETAIL	40
G. PERMIT PROCEDURE	56



c. Sloping roofs that do not exceed the average height of the supporting walls, with an average slope greater than or equal to 1 foot of vertical rise for every 1 foot of horizontal run, and less than or equal to 1 foot of vertical rise for every 1 foot of horizontal run.

c. Three or more roof slope planes.

## 5. Materials and Colors:

**GUIDELINE:** Exterior building materials and colors comprise a significant part of the visual impact of a building. Therefore, they should be aesthetically pleasing and compatible with materials and colors used in adjoining neighborhoods. (o)

### **STANDARD:** (+)

a. Predominant exterior building materials shall be high quality materials. These include, without limitation:

- Brick
- Wood
- Sandstone
- Other native stone
- Tinted, textured, concrete masonry units

b. Façade colors shall be low reflectance, subtle, neutral, or earth tone colors. The use of high intensity colors, metallic colors, black or fluorescent colors is prohibited.

c. Building trim and accent areas may feature brighter colors,



including primary colors, but neon tubing shall not be an acceptable feature for building trim or accent areas.

d. Predominant exterior building materials should not include the following:

- Smooth-faced concrete block
- Tilt-up concrete panels
- Pre-fabricated steel panels

**6. Entryways**

**GUIDELINE:** Entryway design elements and variations should give orientation and aesthetically pleasing character to the building. the standards desirable entryway design features. (o)

**STANDARD: (+)**

Each principal building on a site shall have clearly defined, highly visible customer entrances featuring no less than three of the following:

- a. canopies or porticos
- b. overhangs
- c. recesses\projections
- d. arcades
- e. raised corniced parapets over the door
- f. peaked roof forms
- g. arches
- h. outdoor patios
- i. display windows
- j. architectural details such as tile work and moldings which are integrated into the building structure and design

**C O N T E N T S**

INTRODUCTION 4

AREAS SUBJECT TO REVIEW 5

HISTORIC PRESERVATION 12

MIX OF USES 13

THE STREET 14

CONTEXTUAL DEVELOPMENT 19

URBAN GREENERY 20

UPSTAIRS / DOWNTOWN 21

SIGNAGE 22

APPENDICES 31

A. DRPB ESTABLISHMENT 31

B. HISTORIC SITE ZONING 32

C. VILLAGE DIST. ACT 33

D. VILLAGE DIST. ZONING 35

E. SUMMARY OF DOI GUIDE 38

F. LARGE RETAIL 40

G. PERMIT PROCEDURE 56



- k. integral planters or wing walls that incorporate landscaped areas and/or places for sitting

Where additional stores will be located in the principal building, each such store shall have at least one exterior customer entrance, which shall conform to the above requirements.

#### **7. Back and Side Facades:**

**GUIDELINE:** All facades of a building which are visible from adjoining properties and/or public streets should contribute to the pleasing scale features of the building and encourage community integration by featuring characteristics similar to the front façade.  
(o)

**STANDARD: (+)**

All building facades, which are visible from adjoining properties and/or public streets, shall comply with the requirements of PART I.1. of these Design Standards and Guidelines.

### **PART II. SITE DESIGN AND RELATIONSHIP TO THE SURROUNDING COMMUNIT**

#### **1. Entrances**

**GUIDELINE:** Large retail buildings should feature multiple entrances. Multiple building entrances reduce walking distances from cars, facilitate pedestrian and bicycle access from public sidewalks, and provide convenience where certain entrances offer access to individual stores, or identified departments in a store.



Multiple entrances also mitigate the effect of the unbroken walls and neglected areas that often characterize building facades that face bordering land uses. (o)

**STANDARD: (+)**

All sides of a principal building that directly face an abutting public street shall feature at least one customer entrance. Where a principal building directly faces more than two abutting public streets, this requirement shall apply only to two sides of the building, including the side of the building facing the primary street, and another side of the building facing a second street.

**1. Parking Lot Location**

**GUIDELINE:** Parking areas should provide safe, convenient, and efficient access. They should be distributed around large buildings in order to shorten the distance to other buildings and public sidewalks and to reduce the overall scale of the paved surface. If buildings are located closer to streets, the scale of the complex is reduced, pedestrian traffic is encouraged, and architectural details take on added importance.

**STANDARD (+):**

(b) Parking lot location. No more than fifty (50) percent of the off-street parking area for the lot, tract or area of land devoted to the large retail establishment shall be located between the front façade of the large retail establishment and the abutting streets (the “Front Parking Area.”).

**C O N T E N T S**

INTRODUCTION 4

AREAS SUBJECT TO REVIEW 5

HISTORIC PRESERVATION 12

MIX OF USES 13

THE STREET 14

CONTEXTUAL DEVELOPMENT 19

URBAN GREENERY 20

UPSTAIRS / DOWNTOWN 21

SIGNAGE 22

APPENDICES 31

A. DRPB ESTABLISHMENT 31

B. HISTORIC SITE ZONING 32

C. VILLAGE DIST. ACT 33

D. VILLAGE DIST. ZONING 35

E. SUMMARY OF DOI GUIDE 38

F. LARGE RETAIL 40

G. PERMIT PROCEDURE 56





The Front Parking Area shall be determined by drawing a line from the front corners of the building to the nearest property corners. If any such line, when connected to the plane of the front façade of the building, creates an angle that is greater than one hundred eighty (180) degrees, then the line shall be adjusted to create an angle of one hundred eighty (180) degrees when connected to the plane of the front façade of the building. If any such line, when connected to the plane of the front façade of the building, creates an angle that is less than ninety (90) degrees, then the line shall be adjusted to create an angle of ninety (90) degrees when connected to the plane of the front façade of the building. Parking spaces in the front Parking Area shall be counted to include all parking spaces within the boundaries of the Front Parking Area, including (i) all partial parking spaces if the part inside the Front Parking Area boundary lines constitutes more than one-half (1/2) of said parking space, and (ii) all parking spaces associated with any pad sites located within the Front Parking Area boundaries.

**2. Back Sides:**

**GUIDELINE:** The rear or sides of buildings often present an unattractive view of blank walls, loading areas, storage areas, HVAC units, garbage receptacles, and other such features. Architectural and landscaping features should mitigate these impacts. (o)

**STANDARD: (+)**

The minimum setback for any building façade shall be thirty-five (35) feet from the nearest property line. Where the façade faces

adjacent residential uses, an earthen berm, no less than 6 feet in height, containing at a minimum, evergreen trees planted at intervals of 20 feet on center, or in clusters or clumps shall be provided.

**3. Outdoor Storage, Trash Collection, and Loading Areas:**

**GUIDELINE:** Loading areas and outdoor storage areas exert visual and noise impacts on surrounding neighborhoods. these areas, when visible from adjoining properties and/or public streets, should be screened, recessed or enclosed. While screens and recesses can effectively mitigate these impacts, the selection of inappropriate screening materials can exacerbate the problem. Appropriate locations for loading and outdoor storage areas include areas between buildings, where more than one building is located on a site and such buildings are not more than 40 feet apart, or on those sides of buildings that do not have customer entrances. (o)

**STANDARD: (+)**

- a. Areas for outdoor storage, truck parking, trash collection or compaction, loading, or other such uses shall not be visible from abutting streets.
- b. No areas for outdoor storage, trash collection or compaction, loading, or other such uses shall be located within 20 feet of any public street, public sidewalk, or internal pedestrian way.
- c. Loading docks, truck parking, outdoor storage, utility meters, HVAC equipment, trash collection, trash compaction, and

**C O N T E N T S**

INTRODUCTION 4

AREAS SUBJECT TO REVIEW 5

HISTORIC PRESERVATION 12

MIX OF USES 13

THE STREET 14

CONTEXTUAL DEVELOPMENT 19

URBAN GREENERY 20

UPSTAIRS / DOWNTOWN 21

SIGNAGE 22

APPENDICES 31

A. DRPB ESTABLISHMENT 31

B. HISTORIC SITE ZONING 32

C. VILLAGE DIST. ACT 33

D. VILLAGE DIST. ZONING 35

E. SUMMARY OF DOI GUIDE 38

F. LARGE RETAIL 40

G. PERMIT PROCEDURE 56



other service functions shall be incorporated into the overall design of the building and the landscaping so that the visual and acoustic impacts of these functions are fully contained and out of view from adjacent properties and public streets, and no attention is attracted to the functions by the use of screening materials that are different from or inferior to the principal materials of the building and landscape.

d. Non-enclosed areas for the storage and sale of seasonal inventory shall be permanently defined and screened with walls and/or fences. Materials, colors, and designs of screening walls and/or fences and the cover shall conform to those used as predominant materials and colors of the building. If such areas are to be covered, then the covering shall conform to those used as predominant materials and colors on the buildings.

**1. Pedestrian Flows:**

**GUIDELINE:** Pedestrian accessibility opens auto-oriented developments to the neighborhood, thereby reducing traffic impacts and enabling the development of project a friendlier, more inviting image. This section sets forth standards for public sidewalks and internal pedestrian circulation systems that can provide user-friendly pedestrian access as well as pedestrian safety, shelter, and convenience within the center grounds. (o)

**STANDARD: (+)**

- a. Sidewalks at least 8 feet in width shall be provided along all sides of the lot that abut a public street.
- b. Continuous internal pedestrian walkways, no less than 8 feet in width, shall be provided from the public sidewalk or right-of-way to the principal customer entrance of all principal buildings on the site. At a minimum, walkways shall connect focal points of pedestrian activity such as, but not limited to, transit stops, street crossings, building and store entry points, and shall feature adjoining landscaped areas that include trees, shrubs, benches, flower beds, ground covers, or other such materials for no less than 50% of their length.
- c. Sidewalks, no less than 8 feet in width, shall be provided along the full length of the building along any façade featuring a customer entrance, and along any façade abutting public parking areas. Such sidewalks shall be located at least six (6) feet from the façade of the building to provide planting beds for foundation landscaping, except where features such as arcades or entryways are part of the façade.
- d. Internal pedestrian walkways provided in conformance with Part (b.) above, shall provide weather protection features such as awnings or arcades within 30 feet of all customer entrances.
- e. All internal pedestrian walkways shall be distinguished from driving surfaces through the use of durable, low maintenance surface materials such as pavers, bricks, or scored concrete to enhance pedestrian safety and comfort, as well as the attractiveness of the walkways.

**6. Central Features and Community Spaces:**



**C O N T E N T S**

- INTRODUCTION 4
- AREAS SUBJECT TO REVIEW 5
- HISTORIC PRESERVATION 12
- MIX OF USES 13
- THE STREET 14
- CONTEXTUAL DEVELOPMENT 19
- URBAN GREENERY 20
- UPSTAIRS / DOWNTOWN 21
- SIGNAGE 22
- APPENDICES 31
  - A. DRPB ESTABLISHMENT 31
  - B. HISTORIC SITE ZONING 32
  - C. VILLAGE DIST. ACT 33
  - D. VILLAGE DIST. ZONING 35
  - E. SUMMARY OF DOI GUIDE 38
  - F. LARGE RETAIL 40
  - G. PERMIT PROCEDURE 56

**GUIDELINE:** Buildings should offer attractive and inviting pedestrian scale features, spaces and amenities. Entrances and parking lots should be configured to be functional and inviting with walkways conveniently tied to logical destinations. Bus stops and drop-off\pick-up points should be considered as integral parts of the configuration. Pedestrian ways should be anchored by special design features such as towers, arcades, porticos, pedestrian light fixtures, bollards, planter walls, and other architectural elements that define circulation ways and outdoor spaces. Examples of outdoor spaces and plazas, patios, courtyards, and window shopping areas. The features and spaces should enhance the building and the center as integral parts of the community fabric.  
(o)

**STANDARD: (+)**

Each retail establishment subject to these standards contribute to the establishment or enhancement of community and public spaces by providing at least two of the following: patio\seating area, pedestrian plaza with benches, transportation center, window shopping walkways, outdoor play area, kiosk area, water feature, clock tower, or other such deliberately shaped area and\or a focal feature or amenity that, in the judgment of the Planning and Zoning Board, adequately enhances such community and public spaces. Any such areas shall have direct access to the public sidewalk network and such features shall not be constructed of materials that are inferior to the principal materials of the building and landscape.

**Delivery\Loading Operations**

**GUIDELINE:** Delivery and loading operations should not disturb

adjoining neighborhoods, or other uses. (o)

**STANDARD: (+)**

No delivery, loading, trash removal or compaction, or other such operations shall be permitted between the hours of 10:00 P.M. and 7:00 A.M. unless the applicant submits evidence that sound barriers between all areas for such operations effectively reduce noise emissions to a level of 45 db, as measured at the lot line of any adjoining property.

**C O N T E N T S**

INTRODUCTION 4

AREAS SUBJECT TO REVIEW 5

HISTORIC PRESERVATION 12

MIX OF USES 13

THE STREET 14

CONTEXTUAL DEVELOPMENT 19

URBAN GREENERY 20

UPSTAIRS / DOWNTOWN 21

SIGNAGE 22

APPENDICES 31

A. DRPB ESTABLISHMENT 31

B. HISTORIC SITE ZONING 32

C. VILLAGE DIST. ACT 33

D. VILLAGE DIST. ZONING 35

E. SUMMARY OF DOI GUIDE 38

F. LARGE RETAIL 40

G. PERMIT PROCEDURE 56





# PERMITTING PROCEDURE FLOWCHART

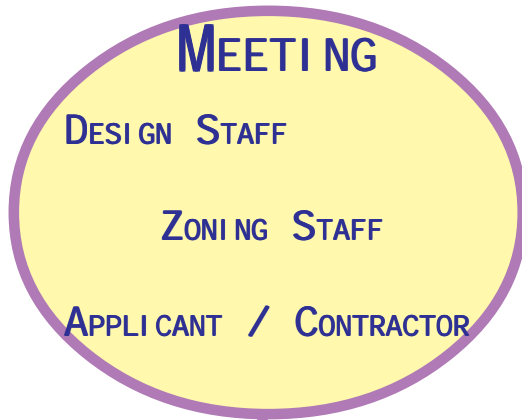

## PRE-APPLICATION CONFERENCE WITH DEPARTMENTAL STAFF. STRONGLY RECOMMENDED.

Meeting with staff of the Planning, Conservation, & Development department *in advance of designing your project* can save you costly delays and wasted time. PCD staff can tell you **before** you hire architects, contractors, or sign designers, whether what you have in mind is legal and/or consistent with the city's plans for your area. The City **is not** responsible for your wasted time or money if you purchase a sign or sign services before consulting city staff on what is allowed.

DESIGN YOUR PROJECT.



The Design Review and Preservation Board meets 2nd Wednesdays at 5:30PM in Room 208 of the Municipal Building. Submit your proposal at least a week in advance of the meeting to allow for distribution. You will need to submit: a scale, color drawing of the project including both plan and elevation and a photograph or map of the project location. Your project also benefits from an in-person presentation to the Board.



Whether or not the Board approves your project, its advisory opinion will be immediately forwarded to Planning and Zoning officials for their check on the project's compliance with P&Z codes and regulations.

Once your application has cleared P&Z, you may take it to the City of Middletown Building Division to obtain a building permit and start your project.

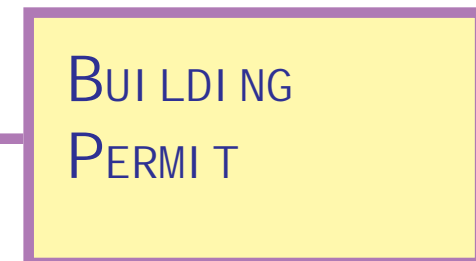

BUILD YOUR PROJECT.

